

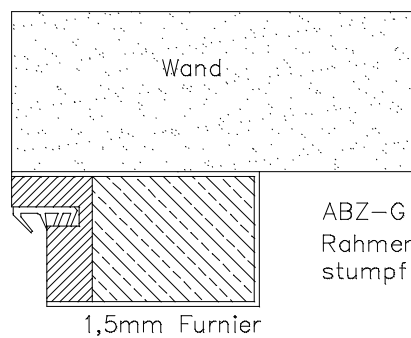

Massiv Blendrahmen ABZ

Ahorn, Birke, Buche, Eiche, Erle, Esche, Fichte, Kiefer, Kirschbaum, Lärche, Nussbaum, Zirbel

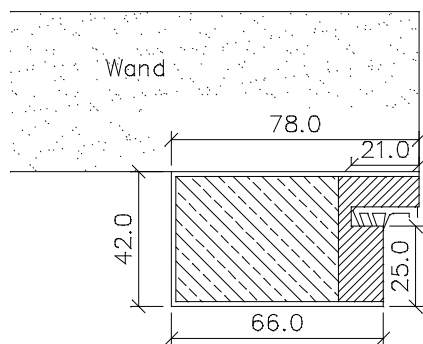

ABZ-G
Rahmenverbindung
stumpf

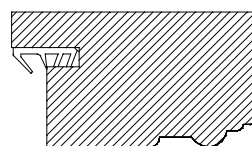

ABZ-LH
Rahmenverbindung
auf Gehrung

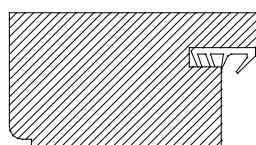

ABZ-INL
Rahmenverbindung
auf Gehrung

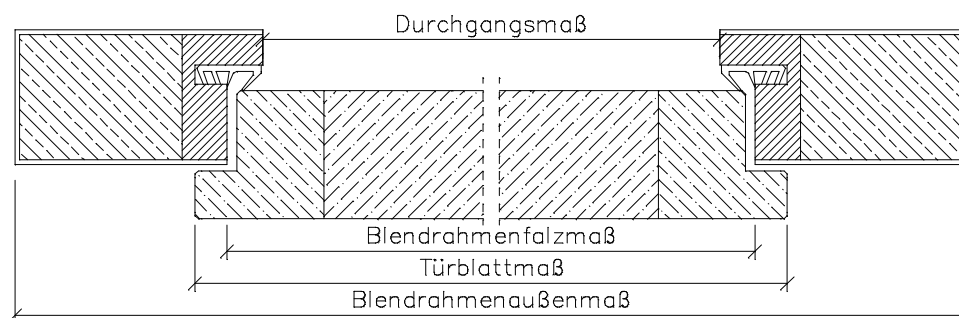

	Türbreite	Blendrahmenfalzmaß	Blendrahmendurchgangsmaß	Blendrahmenaußenmaß
	610	591	566	722
	735	716	691	847
	860	841	816	972
	985	966	941	1097
	610 + 610 (1210)	1191	1166	1322
	735 + 610 (1335)	1316	1291	1447
	735 + 735 (1460)	1441	1416	1572
	860 + 735 (1585)	1566	1541	1697
	860 + 860 (1710)	1691	1666	1822
	985 + 860 (1835)	1816	1791	1947
	985 + 985 (1960)	1941	1916	2072
Höhe	1985	1981	1970	2048